

■ Envelope diagram

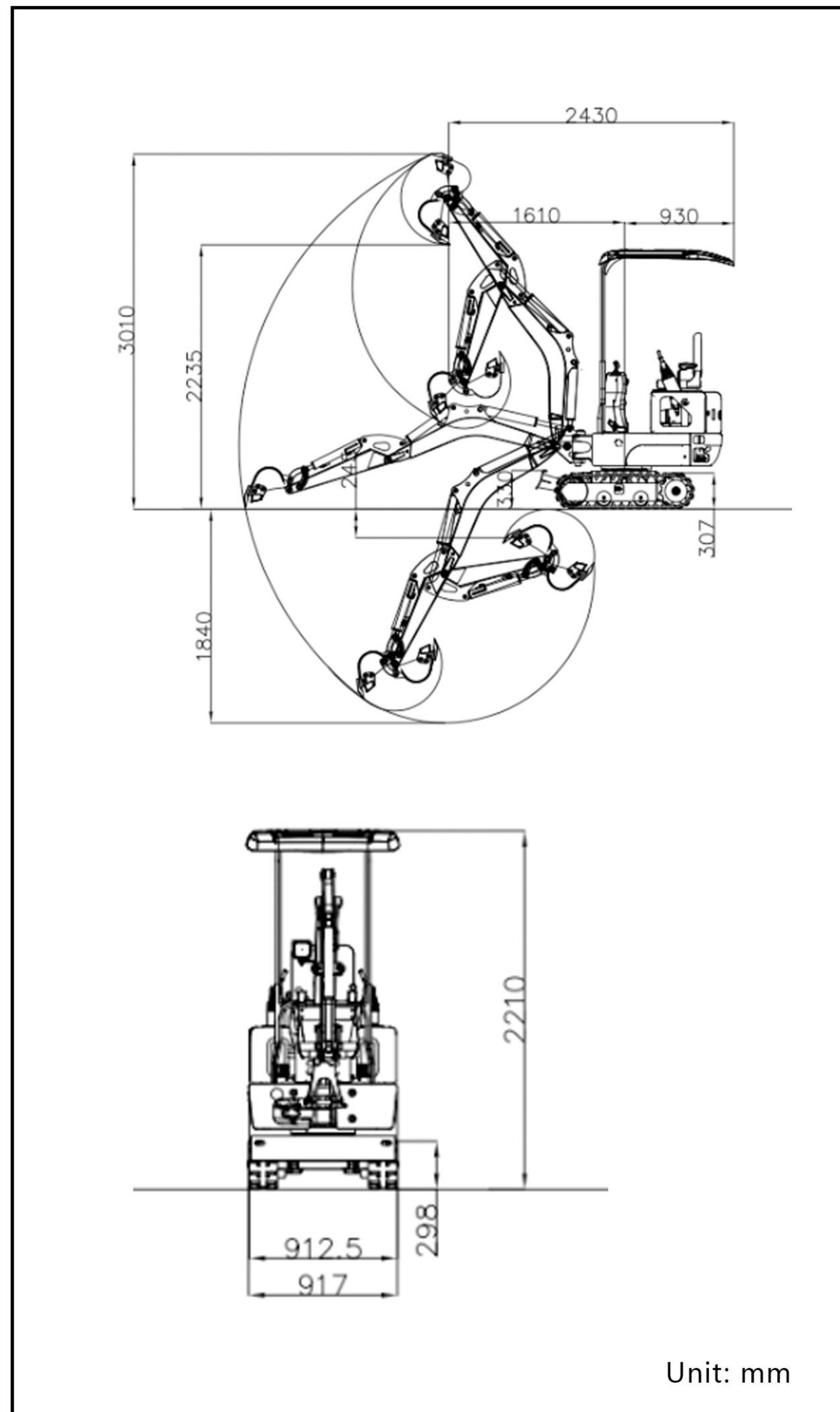

■ Specification

Basic performance parameters	Working weight (kg)	896
	Bucket capacity (m ³)	0.014
	Walking speed low/high (km/h)	0-1.8
	Climbing ability (%)	30%
	Ground specific voltage (Kpa)	25.53
	Maximum excavation force (kN)	9.2
	Maximum excavation radius (mm)	3233
	Maximum excavation depth (mm)	1825
	Maximum excavation height (mm)	3027
	Maximum unloading height (mm)	2255
Body	Maximum deflection angle (°)	119
	Transportation length (mm)	2430
	Transport width (mm)	916
	Transport height (mm)	2209
	Ground clearance of counterweight (mm)	369
	Bucket width (mm)	300
	Boom length (mm)	1477
Engine	Stick length (mm)	800
	Bulldozing board width (mm)	885
	Engine brand	Youpu
	Engine model	192F
	Maximum horsepower (ps)	10.4
	Maximum power (Kw)	7.5
	Maximum speed (rpm)	3000
	Displacement (L)	0.499
	Number of cylinders	1
	Cooling method	Air-cooled
Engine oil change quantity (L)	1.2	
Fuel form	Diesel fuel	
Theoretical fuel consumption (L/h)	0.8-1.2	

Hydraulic system			
Main pump brand	Tianjin Walking/Shengjie	Travel hydraulic motor type	BM6-315
Main pump maximum flow (L/min)	18L/min	Travel motor brand	Paiyi/Zhenjiang Dali
Multi-way valve	2+2+5 joints	Motor displacement	315
Multi-way valve brand	Tengfei	Slewing hydraulic motor type	BM2-315

- Please read the instruction manual carefully and use it correctly.
 - Be sure to fasten your seat belt during operation. ※Except for soft top specification
 - When driving construction machinery with a body weight of less than 3t, please receive "special education on driving construction machinery for vehicles" in advance, and be sure to participate in "skills training for driving construction machinery for vehicles" if it is more than 3t.
- R10-5ECO According to the conditions of the Occupational Safety and Health Act, the body mass may reach 896kg
- In order to prevent breakdowns and accidents, be sure to check the machine regularly.



**EXCELLENT PERFORMANCE,
FULLY MEET THE NEEDS OF
VARIOUS USERS.**



EXCELLENT BASIC PERFORMANCE



[YOUPU ENGINE]

Powerful performance in a compact design. The excellent performance brought by the extra torque greatly contributes to the improvement of workability. At the same time, low fuel consumption, low vibration, low noise, and consideration for the environment have been achieved at a high level.



DIESEL ENGINE ——— 192F

7.5 kw/3000rpm

[NEW APPEARANCE, NEW MATERIAL (FRP)]

- Lightweight and high strength
- preservative
- Good electrical performance
- Good thermal performance



[FULL RANGE OF CE STANDARDS]

- Hydraulic electronic lock
- trumpet
- oil level gauge
- Voltage indication
- Machine pressure warning



[OIL PIPELINE]

The newly upgraded oil pipe direction, the oil pipes are all inside the boom. The oil pipe is not easily damaged and has a longer service life.



RELIABLE JOB PERFORMANCE

[REAR SUPER SMALL TURN]

Minimize the part beyond the outside of the track when turning as much as possible, so the machine can turn safely and securely. Ease of operation is ensured even in narrow working environments

Maximum excavation radius **3233mm**

Maximum excavation depth **1825mm**

Maximum excavation height **3027mm**

Maximum unloading height **2255mm**



[STANDARD ASSEMBLY OF DOZER BLADE]

Thickened dozer blades are suitable for various working environment.

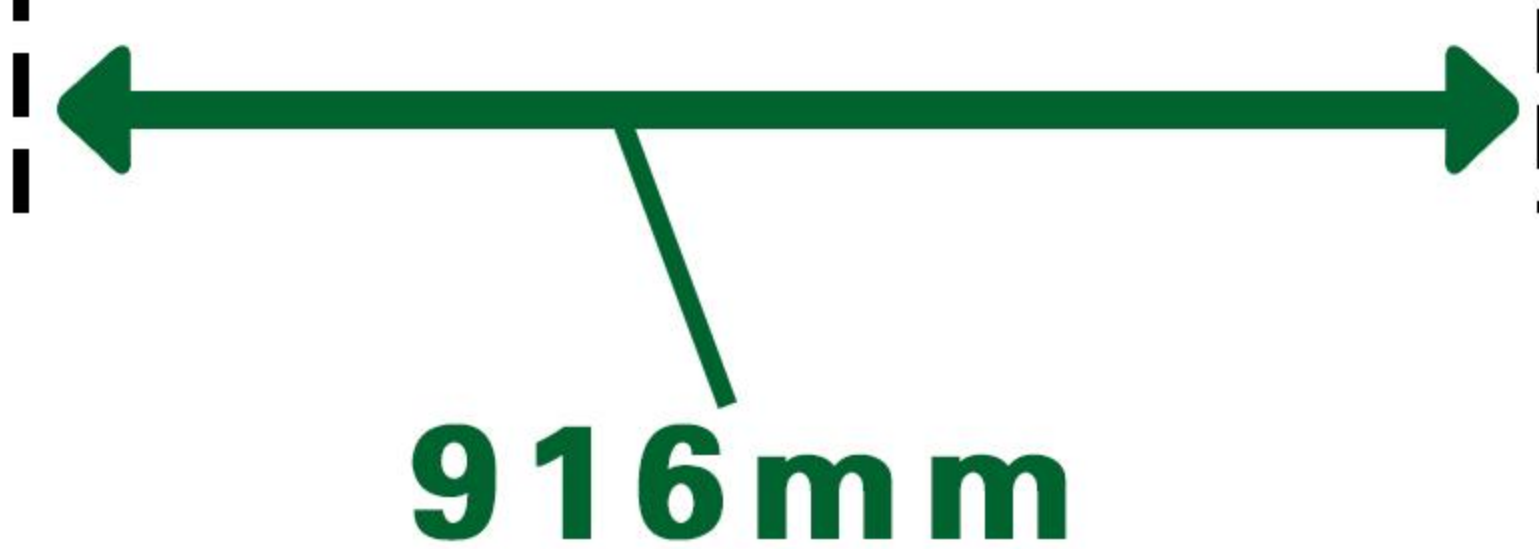

[OIL CYLINDER MOUNTED ON TOP]

Adopts a structure in which the boom cylinder is placed on the back of the boom. When loading soil and sand into the boom of a dump truck, there is no need to worry about damage to the boom cylinder.

[BOOM BRACKET]

It adopts one-piece casting type, which is beautiful and has strong mechanical properties (sturdy)



[THREE-WAY BALL VALVE]

which prevents oil spillage when replacing auxiliary equipment, and has one more hydraulic pipeline.



[BASE MOUNTING HOLE]

Each boom features a hydraulic thumb clamp base mounting hole and replaceable ear plates, streamlining forearm variations and cutting costs for customers.



[MULTILAYER STEEL WIRE OIL PIPE]

Multi-layer steel wire oil pipe is added inside natural rubber, with a pressure resistance of 70MPa. The oil pipe is built-in to effectively protect the oil pipe.



[BIG ARM SIDE SWING]

The big arm can be swung sideways for greater flexibility during work and can dig into corners.



EXCELLENT OPERABILITY AND COMFORT



Bilateral two-hand operation + pedal walking + electronic mechanical lock, with operating hand rest, ergonomic design, long-term operation without fatigue



[Flip-forward seat]

Adjustable seat with safety belt ensures comfort and safety during long working hours. Can be flipped forward for easy maintenance.



[Three control valves]

The three control valves are interconnected and do not interfere with each other. The compound action is smooth and the comfort is good.



[Plastic Fuel Tank]

Plastic diesel tanks and hydraulic oil tanks ensure the cleanliness of fuel and hydraulic oil, protect hydraulic components from wear and tear, increase service life



[Back cover and shell]

Left-hand opening rear door, simple operation and convenient maintenance. The inner side of the protective cover is made of new fiberglass material, which reduces machine noise and heat conduction



R10-5 ECO MINI EXCAVATOR

Within reach
Larger lifting force, larger digging range

Easily removable roof for
low-space work

Pilot operation
Smooth operation, energy
saving and high efficiency

The inner side of the protective cover is
made of new FRP material to reduce
machine noise and heat conduction.

Large bucket capacity significantly
improves excavation efficiency

Thickened new tracks are wear-resis-
tant, pressure-resistant and slip-resis-
tant to meet your various needs.

The new structure design of the chassis reduces the
stress concentration points and improves the durability
and stability of the equipment.

